

SWIVEL FRAME TIE

Model # OTSFT

PATENT # 6,928,783,B2

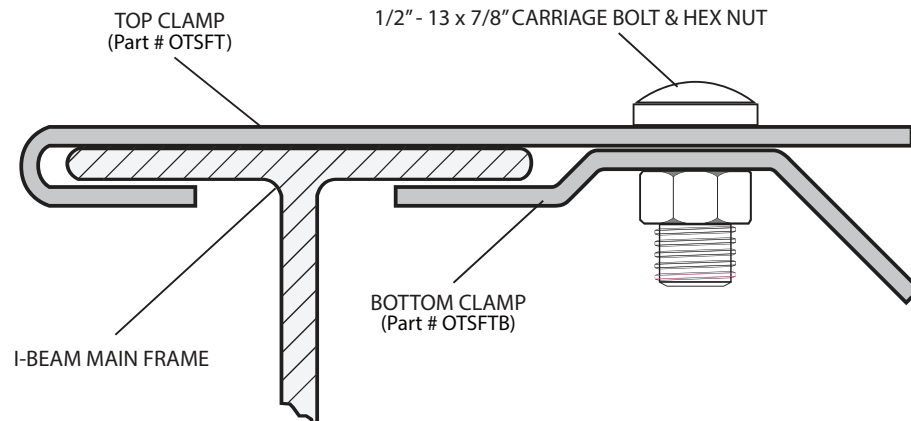

STEP 1: Place top clamp over the top of the I-Beam.

STEP 2: Place the carriage bolt in the first exposed hole closest to the I-Beam. (Top clamp works on I-Beam sizes 2 3/4" through 4".) (Part # EXTOTSFT extended top clamp works on I-Beam sizes 7" - 9")

STEP 3: Attach the bottom clamp (with pre fabricated strap) by tightening the carriage bolt and hex nut.

STEP 4: The Swivel Frame Tie and attached strap should be installed perpendicular to the I-Beam when possible, however there is an allowance of 7.5 degrees in either direction from perpendicular.

NOTE: DO NOT WRAP STRAP AROUND FRAME. The maximum allowable working load capacity of the OTSFT is 3150 lbs., with no more than 2% elongation and shall withstand 50% overload (4725 lbs).

OTI anchors and components will perform at this design load regardless of the wind pressures and distance from the coastline, provided that the number, location and spacing of the components is such that the design load of 3150 is not exceeded.

Fastener required to assemble both parts 1/2" - 13 x 7/8" carriage bolt and hex nut (abstract of SAE J429 1985) coating ASTM standard B633-85 (re-approved 1994).

SWIVEL FRAME TIE

Model # 2001

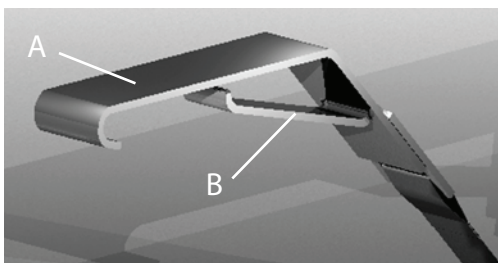

A = Top jaw (OT2001UJ)
Extended Top Jaw (OT2001LUJ)

B = Bottom jaw (OT2001L) of Swivel Clamp
with factory installed strap

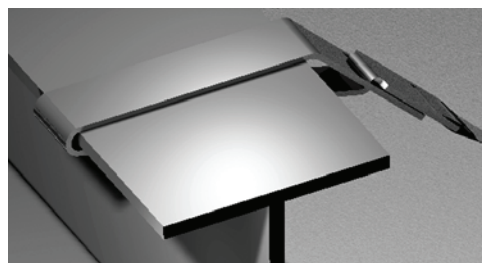

STEP 1: Slide top jaw over top flange on the I-Beam then pull to secure.

STEP 2: Insert bottom jaw into slot of top jaw at a 45 degree angle.



STEP 3: Rotate bottom jaw into lock position with top jaw.

STEP 4: Refer to strapping page for proper installation of strap.

NOTE: This frame clamp (Part # OT2001UJ) was designed to be used on 2 3/4" (2.75") minimum flange width and 4" maximum flange width. The bottom jaw of the clamp can swivel up to 10 degrees maximum. Frame Clamp (Part # OT2001LUJ) for a double beam (2) - 4" flange welded beams application.

I-BEAM FRAME CONNECTORS

FRAME TIE (OTFT-1)

- STEP 1 : Attach frame clamp (hook) inside top flange of home frame.
 STEP 2: Place strap between the frame and home as shown. (wrapping I-beam)
 STEP 3: Pull strap tight and attach to the anchor tension head. (Refer to strapping page for proper installation of strap.)
- NOTE: The frame tie has an allowable working load of 3150 lbs., with no more than 2% elongation and shall withstand a 50% overload (4725 lbs. total)

OTFT-1 with factory installed strap

Enlarged End View of I-Beam Floor

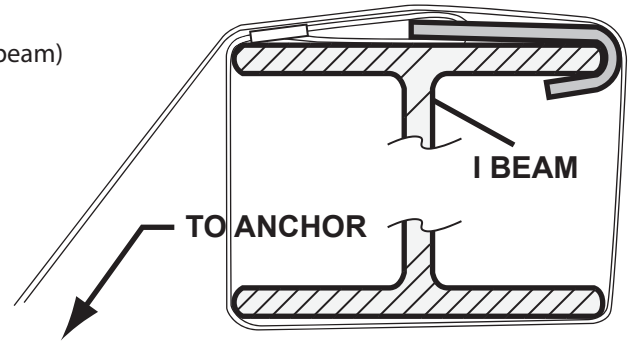

DOUBLE SLOTTED BUCKLE (OTST-1)

INSTALLATION INSTRUCTIONS



- STEP 1 : Thread frame tie strap through buckle as shown.
 STEP 2: Thread long end of strap between the frame and floor of home.
 STEP 3: Ensure proper strap tension. (Refer to strapping page for proper installation of strap.)

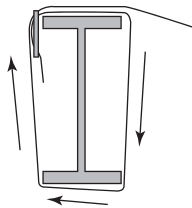

NOTE: The maximum allowable working load capacity of the strap woven through the slots in the buckle is 3150 lbs., with no more than 2% elongation and shall withstand a 50% overload (4725 lbs. total)

FACTORY CRIMPED DOUBLE SLOTTED BUCKLE (OTST-1)

INSTALLATION INSTRUCTIONS

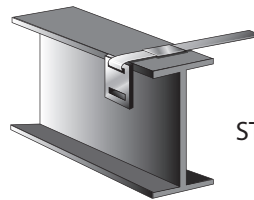

- STEP 1 : Install strap by pushing the end of the strap between the inside of the frame I-beam and the floor.
 STEP 2: Position the buckle at the upper end of the I-beam frame. Wrap the end of the strap through the slot in the buckle as shown. Push the end of the strap in between the I-beam and floor.

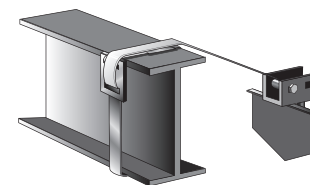
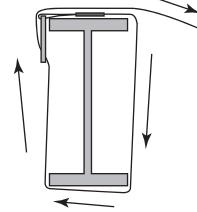

NOTE: The maximum allowable working load capacity of the strap woven through the slots in the buckle is 3150 lbs., with no more than 2% elongation and shall withstand a 50% overload (4725 lbs. total)

MANUFACTURED HOME

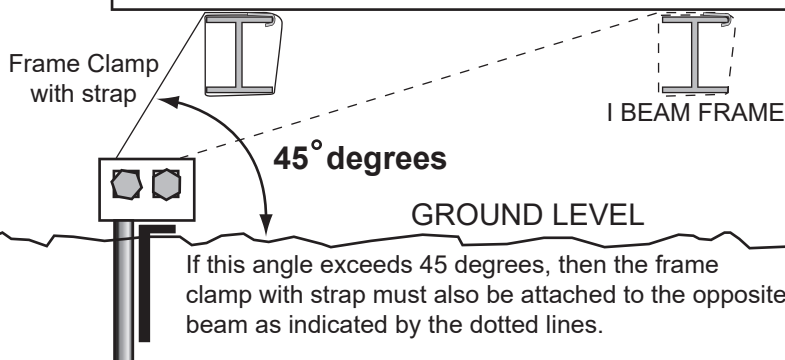

- 1) The tensioning bolt can be inserted in the head from either side.
- 2) In areas of severe cold weather where possible damage could occur from frost heave, the homeowner should be prepared to adjust tension on the straps to take up slack.