

**For use on all Mobile and Manufactured Homes, including HUD approved Homes and Modular Buildings
Patent #5503500**

GENERAL INSTRUCTIONS:

1. All pads are to be installed flat side down, ribbed side up.
2. The ground under the pads should be leveled as smoothly as possible with all vegetation and debris removed. Pads to be placed on evenly compacted soil, at or below the frostline unless otherwise protected from frost by controlling the temperature and/ or moisture content of the soil underneath the home.
3. Pier & pad placement will be determined by the manufactured homes' written set-up instructions or any local or state codes.
4. Center the blocks on the ABS pad and complete pier.
5. A pocket penetrometer may be used to determine the unconfined compressive strength of the soil. If no soil testing equipment is available, use an assumed soil value of 1,000 lbs. / sq. ft.

NOTES:

1. All pad sizes shown are nominal dimensions and may vary slightly.
2. The maximum deflection in a single pad is 3/8" measured from the highest point to the lowest point of the top face.
3. Pad loads are the same when using single stack or double stack blocks.
4. The maximum load at any intermediate soil value may be calculated between the next lower and next higher soil values given in the table below.
5. Any ABS pad configuration may be used to replace a home manufacturer's recommended concrete or wood base pad.
6. The open cells between the ribs on the upper side of the pads may be backfilled with soil or sand.
7. If soil capacities exceed 3,000 lbs. / sq. ft., use the 3,000 lbs. / sq. ft. soil values from the table.
8. Any pad may be stacked directly on top of an identical pad. The second pad should also be installed flat side down. Such a configuration provides the same allowable load capacity as a single pad.
9. Gravel can be used in place of below-grade concrete footings. Reference IRC AE502.3 & IRC R403.4.1 for proper footing installation and material requirements. Always refer to the local authority having jurisdiction (LAHJ).

ABS Pier Pad Single & Double CMU Pier Models and Maximum Load Capacities:

Model	Dimension (in. x in.)	Shape	Maximum Pier Load (lbf)			
			Soil Unconfined Compression Strength (psf)			
			1,000	2,000	2,500	3,000
1055-14**	16 x 16	Square	1,780**	3,560**	4,450	5,340
1055-23	16 x 18.5	Oval	2,000	4,000	5,000	6,000
1055-9**	18.5 x 18.5	Square	2,375**	4,750**	5,935	7,100
1055-16	17 x 22	Oval	2,500	5,000	6,250	7,500
1055-21	17.5 x 22.5	Oval	2,667	5,334	6,668	8,000
1055-7**	20 x 20	Square	2,750**	5,500**	6,875	8,250*
1055-17	17.5 x 25.5	Oval	3,000	6,000	7,500	9,000*
1055-13**	24 x 24	Square	4,000**	8,000**		
1055-26	24 x 24	Square	4,000	8,000	10,000*	12,000*
1055-22	21 x 29	Oval	4,000	8,000	10,000*	12,000*
1055-20	23.25 x 31.25	Oval	4,698	9,396*	11,745*	14,094*

All pads can be utilized with a single CMU, except where * indicates double-CMUs are required.
** Indicates when and at what capacities steel piers can be used.

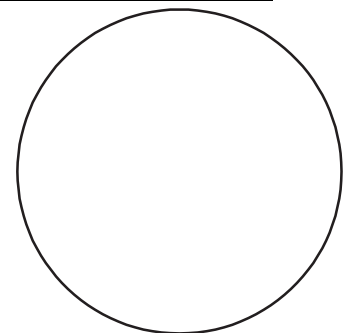
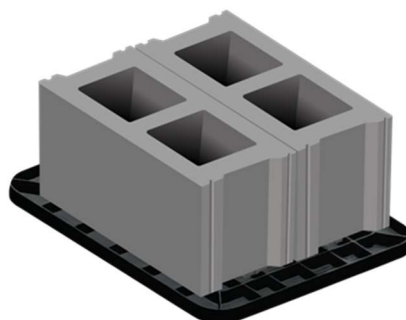
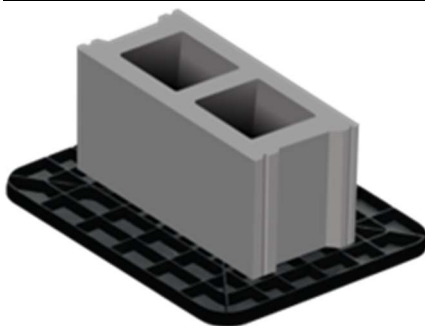

ENGINEER APPROVAL

Multi-Pad Configurations:

16" x 18.5" Multi-Pad Configuration:

Dimension (in. x in.)	Area (ft ²)	Model	Multi-Pad Configuration	8" Cell Block	Soil Bearing Value	Maximum Load
16" x 18.5"	2	1055-23	32" x 18.5" 3 Pad Configuration	Single Stack	1,000 lbs./ft ²	4,000 lbs.
32" x 18.5" (3 pad)	4			Double Stack	2,000 lbs./ft ²	8,000 lbs.*

The 32" x 18.5" pad configuration is formed by using (3) 16" x 18.5" ABS Pads. Place (2) 16" x 18.5" pads side by side, and place (1) 16" x 18.5" pad on top, laid in the opposite direction of the bottom pads.

17" x 22" Multi-Pad Configuration:

Dimension (in. x in.)	Area (ft ²)	Model	Multi-Pad Configuration	8" Cell Block	Soil Bearing Value	Maximum Load
17" x 22"	2.5	1055-16	34" x 22" 3 Pad Configuration	Single Stack	1,000 lbs./ft ²	5,000 lbs.
34" x 22" (3 pad)	5			Double Stack	2,000 lbs./ft ²	10,000 lbs.*

The 34" x 22" pad configuration is formed by using (3) 17" x 22" ABS Pads. Place (2) 17" x 22" pads side by side, and place (1) 17" x 22" pad on top, laid in the opposite direction of the bottom pads.

17.5" x 25.5" Multi-Pad Configuration:

Dimension (in. x in.)	Area (ft ²)	Model	Multi-Pad Configuration	8" Cell Block	Soil Bearing Value	Maximum Load
17.5" x 25.5"	3	1055-17	35" x 25.5" 3 Pad Configuration	Single Stack	1,000 lbs./ft ²	6,000 lbs.
35" x 25.5" (3 pad)	6			Double Stack	2,000 lbs./ft ²	12,000 lbs.*

The 35" x 25.5" pad configuration is formed by using (3) 17.5" x 25.5" ABS Pads. Place (2) 17.5" x 25.5" pads side by side, and (1) 17.5" x 25.5" pad on top, laid in the opposite direction of the bottom pads.

Notes:

1. General instructions (on reverse) apply when installing all multi-pad configurations.
2. *Concrete blocks are only rated at 8,000 pounds. All loads at 8,001 pounds or higher must be double stacked.

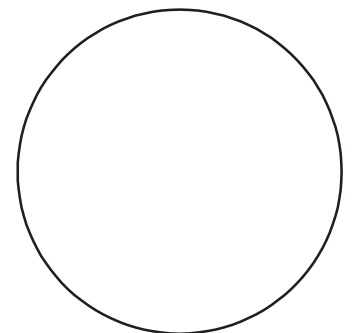
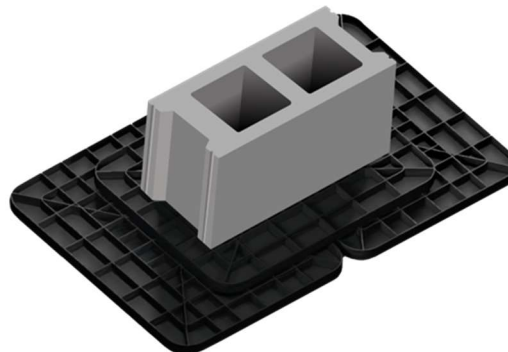

ENGINEER APPROVAL