

OLIVER TECHNOLOGIES, INC.
Installation Instructions for 1100 Series All Steel Foundation System
Wind Zones I & II

SPECIAL CIRCUMSTANCES: If the following conditions occur – STOP! Contact Oliver Technologies at 1-800-284-7437

- › Any frame pier height exceeds 48" › Single section roof pitch 5:12 or greater
- › Soil conditions less than 4B
- › Roof eaves exceed 12" › Location is within 1,500' of coastline
- › Sidewall height exceeds 9' (108")
- › Home criteria does not match instructions

The 1100 series ASFS Offers 3 packages:

1. **1100ITV** (1 Arm/Brace– Lateral) see 1,3, 9-12
2. **1100IV** (3 Arm/Brace– Lateral and Longitudinal- Replaces Pier) 1,3, 4a-8a, 9-12
3. **1100 SOLO** (2 Arm/Brace– Lateral and Longitudinal) 1-3, 4b-8b, 9-12

INSTALLATION OF GROUND PAN FOR DIRT SET

1. Remove weeds and debris in an approximate 3' square to expose firm, level undisturbed soil or controlled fill for each ground pan. The 1100 Pan is equivalent to a 21" x 21" footing. Top of ground pan (C) must be installed at ground level or per local jurisdiction. Ground pan can be installed below grade and backfilled as long as a distance between top of ground pan and bottom of frame does not exceed 48".
2. If using the SOLO longitudinal brace, ensure the longitudinal hardware is installed on the correct side. Hold lock washer flush to pan, hand tighten bolt and washer to lock washer. Hammer bolt head until washer and bolt are flush with pan. Refer to Diagram 1A.
3. Place center ground pan (C) directly below chassis I-Beam. Press or drive pan completely into soil until flush with or below soil.

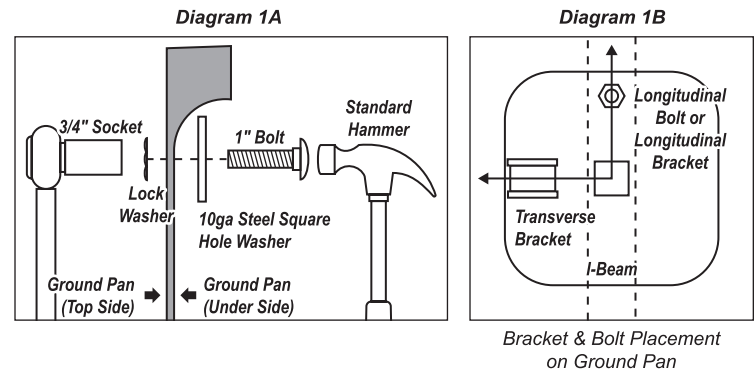

INSTALLATION OF LONGITUDINAL "V" BRACE SYSTEM

NOTE: For homes with reinforced I-beams, the 1100-10A-P longitudinal I-beam connector will replace the standard I-beam connector.

NOTE: For homes with double I-beams, the extended longitudinal I-beam connector hardware will replace the standard I-beam hardware. Please refer to addendum B for proper installation.

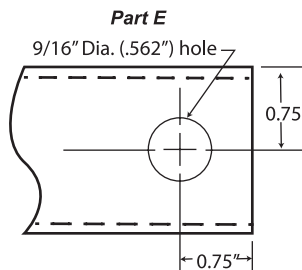

PIER HEIGHT (40° MIN. - 60° MAX.)	1.50" TUBE LENGTH
14" - 18"	20"
18" - 25"	28"
24" - 35"	39"
30" - 40"	44"
36" - 48"	54"

PIER HEIGHT = The dimension from the top of the pan to the bottom of the I-Beam

*Vertical pier load should not exceed 4,800lbs

- 4a. Select the correct square tube brace (E) length for set-up (pier) height at support location.
 - 5a. Install end of the 1.50" square tubes (E) into the "V" bracket (J), insert carriage bolt and leave nut loose for final adjustment.
 - 6a. Place both longitudinal I-Beam connector (F) loosely on the bottom flange of the I-Beam.
 - 7a. Attach the selected 1.5" tubes (E) to the I-Beam connectors (F) and fasten loosely with bolts and nuts.
- NOTE:** The ground pan must be level in both directions to ensure the angle markings on the center point connector are correct from the horizontal plane of the pan. The angle is not to exceed 60° and not less than 40°. The "V" bracket is stamped with angle marks to use as a guide. Use an Angle Finder to verify proper angle. Use proper length tube or cut and drill tube to achieve proper length. (The tube may be cut using any appropriate steel cutting method such as reciprocating saw, band saw etc. New holes must be drilled to the dimension and at the location as shown for part (E).

- 8a. The V-brace system functions as a structural pier beneath the home and must be loaded in the same manner as all other piers. After leveling, stop approximately 1/2" before the home is fully lowered onto the piers. Tighten all hardware securely using standard hand tools, ensuring all nuts and bolts are tightened at least 1½ to 2 full turns past hand tight. Once all hardware is secure, lower the home completely onto the piers to ensure full load transfer.

INSTALLATION OF 1100 SOLO LONGITUDINAL BRACE

- 4b. Determine the correct length of the longitudinal brace (K) to be installed based on pier height.
- 5b. Make sure the longitudinal bolt (L) is centered under the I-Beam.
NOTE: It is required that each longitudinal brace is installed in opposite directions underneath the home.
- 6b. Place the flattened end of the longitudinal brace over the bolt (L) on the ground pan and loosely secure with provided nut and washer.
- 7b. Place both longitudinal I-Beam connectors (F) loosely on the bottom flange of the I-Beam.
- 8b. Attach the opposite end of the longitudinal brace to the bottom flange of the I-Beam using the longitudinal I-Beam connectors (F) with bolt and nut. Using standard hand tools, tighten all nuts and bolts.

PIER HEIGHT (15° MIN. - 45° MAX.)	LONGITUDINAL BRACE LENGTH
12" - 24"	39"
12" - 32"	44"
12" - 40"	54"
12" - 48"	65"

PIER HEIGHT = The dimension from the top of the pan to the bottom of the I-Beam

NOTE: Angle of longitudinal brace must be between 15° and 45° from horizontal plane.

INSTALLATION OF (LATERAL) TELESCOPING TRANSVERSE BRACE SYSTEM (1100 ITV)

NOTE: For homes with double I-beams, the extended lateral I-beam connector kit will replace the standard I-beam connector in Wind Zone I. Please refer to *addendum A* for proper installation.

9. Select the correct transverse brace (H). The 60" sections are standard and can be installed on frame widths of 95.5" to 99.5" An optional 72" brace is available and can be used on frame widths of 99.5" to 118".
10. Install the 1.5" transverse brace (H) to the ground pan connector (D) with the 2.5" bolt and nut.
11. Slide 1.25" transverse brace into the 1.5" brace and attach to adjacent lateral I-beam connector (I) with 2.5" bolt and nut. Next, install the I-beam connector over the top flange of the I-beam and secure with Flat Clamp (P) using included 1.5" bolt and nut.
12. Secure 1.5" transverse brace using four (4) 1/4"-14 x 3/4" self-tapping screws in pre-drilled pilot holes. Drill speed should not exceed 1,800 RPM.

INSTALLATION USING CONCRETE (ICV)

The concrete footer, runner or slab that has a minimum of 2900 cu. in., with a minimum depth of 6" at each system location. The surface of the footing shall be large enough to support the pier load and allow at least 4" from the concrete bolt to the edge of the concrete (ie. 22" x 22" x 6" footer). The concrete shall be a minimum of 2500 psi mix (pre-blended sacked concrete mix is acceptable). Special inspection of footing is not required. If the 1100ITC Transverse system is to be installed without the use of a longitudinal system, it MUST be installed on same footing within 18" of pier. Provide a minimum spacing of 4" center-to-center between wedge bolt installations, and maintain a minimum distance of 4" from any concrete edge to the centerline of the wedge bolt.

LONGITUDINAL (V)

When using the 1100 wet set bracket, simply install the bracket in runner/footer OR when installing in cured concrete, use the 1100 dry set bracket. The 1100 dry set bracket is attached to the concrete using (2) 1/2" X 3" concrete wedge bolts. Center bracket under I-Beam in desired location. Mark bolt hole locations, then using a 1/2" masonry bit, drill a hole to a minimum depth of 3". Be sure all dust is blown out of the holes. Place wedge bolts into drilled holes, then place 1100 bracket onto wedge bolts and start wedge bolt nuts. Take a hammer and lightly drive the wedge bolts down by hitting the nut (Do not hit the top of threads on bolt). Complete by tightening the nuts.

LONGITUDINAL (SOLO)– Dry Concrete Only

Position longitudinal concrete bolt for installation and drill ½" hole. 3" deep into concrete. Make sure that the Longitudinal bolt is centered under the I-Beam. Be sure all dust is blown out of the holes. Place wedge bolt into drilled hole. Make sure starter nut is threaded onto wedge bolt. Take a hammer and lightly drive the wedge bolt down by hitting the nut (do not hit the top of threads on bolt). Leave approximately 1" of wedge bolt threads above surface. Remove starter nut from wedge bolt and follow applicable instructions based on system being installed.

LATERAL (Transverse Brace)

For wet set installation set the transverse connector bracket into runner/footer at desired location. For dry set installations, the transverse connector bracket is attached to the concrete using (2) 1/2" X 3" concrete wedge bolts. Mark bolt hole locations, then using a 1/2" masonry bit, drill a hole to a minimum depth of 3". Be sure all dust is blown out of the holes. Place wedge bolts into drilled holes, then place transverse connector bracket onto wedge bolts and start wedge bolt nuts. Take a hammer and lightly drive the wedge bolts down by hitting the nut (do not hit the top of threads on bolt.) Complete by tightening the nuts.

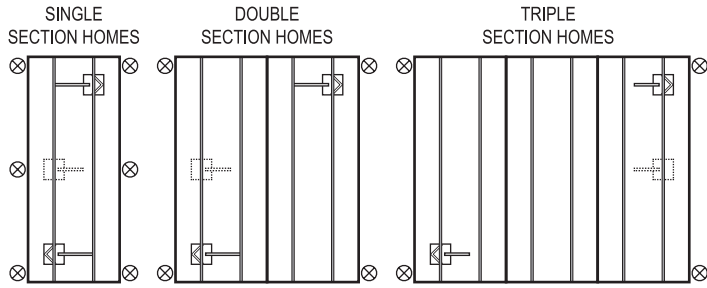

**REQUIRED NUMBER AND LOCATION OF MODEL
1100 SERIES BRACES FOR 4/12 & 5/12**

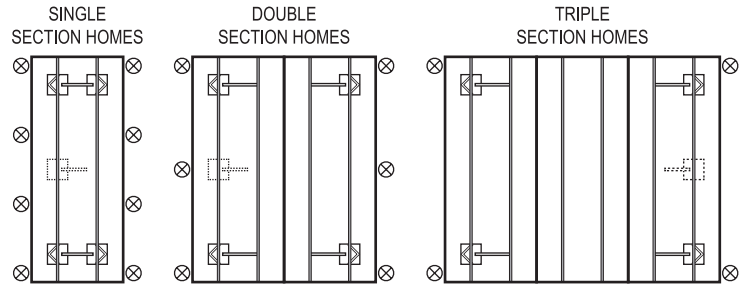

**REQUIRED NUMBER AND LOCATION OF MODEL
1100 SERIES BRACES FOR 6/12 & 7/12**



LEGEND

1.  Location of ASF Model 1100 (Lateral and Longitudinal Bracing) or 1100 T (Lateral only) up to 76'.
2.  For homes longer than 76' or with roof pitches ranging from 4.37/12 (20°) to 5/12, an additional ASF Model 1100 T System (Lateral only) must be positioned at roughly the midpoint of the house. This additional system can be mounted on either exterior beam. See illustration above.
3.  Installation on all homes require a minimum number of uplift anchors in WZ I for enhanced wind protection. Strap angle 75-90°. Check anchor tables for details.

Wind Zone I Vertical Anchor Table

Home Section	Home Width	4:12 Roof Pitch		5:12 Roof Pitch		6:12/7:12 Roof Pitch	
		Home Length (Act. Box Size)	Anchors Per Side	Home Length (Act. Box Size)	Anchors Per Side	Home Length (Act. Box Size)	Anchors Per Side
Single	12' (Nominal)	up to 57'	3	<i>Contact Oliver</i>			
	140"	58'-88'	4				
	14'-18' (Nominal)	up to 66'	3	<i>Contact Oliver</i>			
	156" to 210"	67'-90'	4				
Double	20' (Nominal)	up to 90'	2	up to 90'	3	up to 63'	3
	(2)118"					64'-90'	4
	24'-32' (Nominal)	up to 90'	2	up to 64'	2	up to 73'	3
	(2)140" to (2)186"					65'-90'	3
Triple	36'-48' (Nominal)	up to 90'	2	up to 90'	2	up to 90' 2	
	(3)140" to (3)186"						

IMPORTANT: System Uplift Anchors are to be installed to the bottom of the rim joist, at the sidewall, with a 3150 lb rated bracket and specified lag bolts. Corner anchors should be installed within 3' of the end of the home, with any additional anchors installed as evenly as possible per side.

NOTE: Alternative strapping methods are also approved to protect against uplift, including moving sidewall brackets and vertical straps inward up to 10" and locating the sidewall bracket on a floor joist.



INSTALLATION OF THE OT SWB SIDEWALL BRACKET

1. Locate the desired location under home, on underside of the rim or floor joist.
2. Position sidewall bracket with two holes centered on joist. Orientation of sidewall bracket does not affect performance.
3. Mark the center of both holes and pre-drill two pilot holes using a 15/64" drill bit.
4. Install (2) two lag bolts into pre-drilled holes to secure sidewall bracket.
Minimum size: 3/8"-7 x 3 1/2" with a minimum of 3 1/4" threads.
5. Refer to anchor and strapping installation instructions for proper installation of anchor and strap.
NOTE: The OT SWB sidewall bracket can be used in place of any sidewall or marriage line bracket that is rated at or below 3150 lbs. working load.

NOTE:

- A. Installation of the longitudinal system eliminates the need for all longitudinal anchors.
- B. Installation of the transverse system eliminates the need for all lateral anchors, diagonal frame ties and stabilization plates except when noted. (Note C)
- C. All other home manufacturer's instructions for installation of stabilizing devices must be followed, including installation of vertical tie-down anchors, and mating line column, shear wall or center-line tie-down anchors. NOTE WIND ZONE II: ALL VERTICAL ANCHORS (NOT TO EXCEED 8' SPACING) MUST BE INSTALLED PER MANUFACTURERS INSTALLATION INSTRUCTIONS!
- D. If the home manufacturer's installation instructions are not available, the home must be installed in accordance with any state promulgated rules or as required by the authority having jurisdiction.
- E. When the length of home exceeds 76', sidewall height exceeds 96" or the roof pitch is between 4.37/12 (20°) and 5/12, add 1 transverse system (see location diagrams above) 6/12: a total of 4 Transverse & 3 Longitudinal systems are needed & 7/12: a total of 5 Transverse & 3 Longitudinal systems are needed. (Longitudinal portion only required when longitudinal bracing is required by home manufacturer).
- F. An alternative method using the 1100 CVD anchors (dry set) or 1100 CVW (wet set) may be used on a footing size of 16" diameter x 24" depth. These brackets are designed for lateral and longitudinal protection.
- G. It is recommended that the systems be installed at the 2nd pier in from each end of the house. However, they may be installed at any location at least 2', but not more than ¼ the house length, in from the ends of the home.

STATE OF MICHIGAN ONLY: As required by Section 1805.2 of the 200 Michigan Building Code, the depth of the footer shall be a minimum depth of 42" below grade, except that the authority having jurisdiction may approve a lesser depth based on known prevailing soil and weather conditions, or as provided by the exception under Section 1805.2.1 of the Code.

STATE OF NORTH CAROLINA ONLY: Tubing must be galvanized and, when the manufacturer's installation instructions are not available, vertical wall tie-downs must be installed not to exceed 8' on center. (Wind Zone II)

STATE OF IDAHO ONLY: Concrete must be a minimum of 8" in depth.

STATE OF CALIFORNIA ONLY: Refer to specific CA instructions for proper installation.

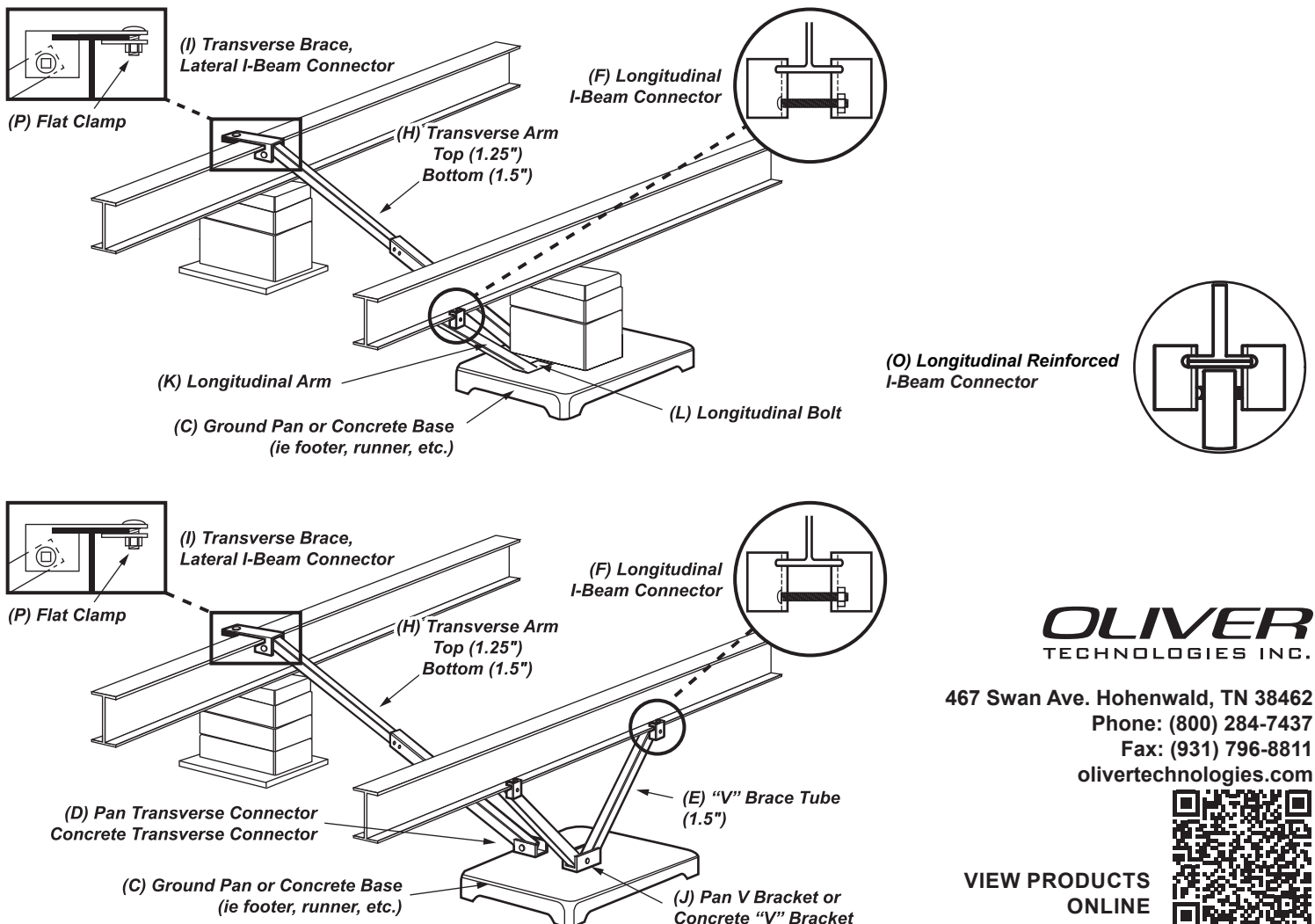

OLIVER
TECHNOLOGIES INC.

467 Swan Ave. Hohenwald, TN 38462
Phone: (800) 284-7437
Fax: (931) 796-8811
olivertechnologies.com



VIEW PRODUCTS
ONLINE

DISCLAIMER: All Oliver Technologies products must be installed in accordance with Oliver Technologies installation instructions, the home manufacturer's installation requirements, and all applicable local, state, and federal codes and regulations. Products shall not be modified or used outside their intended application. Failure to follow installation requirements may result in property damage, product failure, serious injury, or death.